



**CAMLOCK**  
SYSTEMS

**PRODUCT SPECIFICATION**

Series 63 Cam Lock

# SERIES 63

**NEW BRASS CAM LOCK  
HOUSES OUR FLAGSHIP,  
PATENTED AXIAL MECHANISM.**



## OVERVIEW

**Anti-manipulation, key control, high security.**

Camlock's flagship AXIAL pin tumbler mechanism utilised a series of single, bump-resistant, singular pins, a set of anti-manipulation features surrounding the core, and an anti-drill pillar. **Also available in 25mm and 30mm body lengths. A wide range of compatible cams are available to order with this product.**

### Product features

- o Stainless steel anti-drill pillar to deflect drilling
- o No shear line = bump resistant
- o Ideal for superior key control. Can cross suite with Series 65
- o Housed in a high-quality brass shell
- o Red indicator for accurate key entry alignment

## TECHNICAL DATA

Number of key differs	over 5.7 million
Protective features	Stainless steel anti-drill pillar
Mechanism	Axial
Body material	Brass
Finish	Satin chrome plated
Patent protection	Yes
Key registration	Yes
Cross suiting (within the Axial family)	Yes
Master keying	No
Key suite options	Keyed alike and keyed to differ
Body length	18mm, 25mm, 30mm
Fixing hole dimensions	Standard 19mm x 16mm double D punch
Lock fixing	Body nut (supplied)
Key operations	Three options available

**SMARTER  
LOCKING**



## TECHNICAL DRAWINGS

### Series 63 18mm

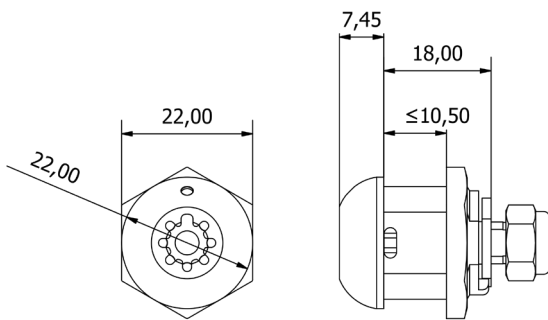

### Series 63 25mm

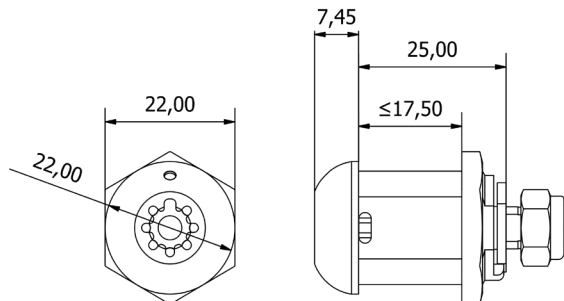

### Series 63 30mm

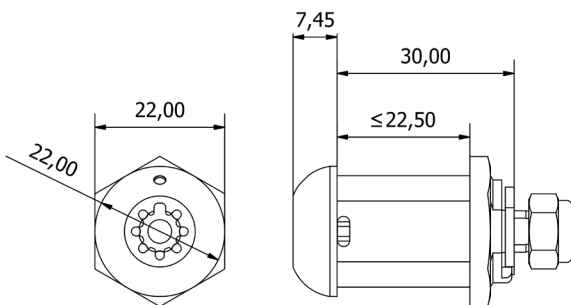

## ADDITIONAL PRODUCT IMAGES

## KEY OPERATIONS

Additional free positions (key movements: 4,5,6 and 9) available to special order, subject to quantity.

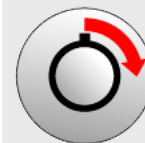

### Key movement: 1

Key starting position: 12 o'clock  
Key rotation: 90°  
Key ending position: 3 o'clock  
Key when unlocked: Trapped

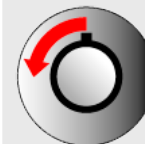

### Key movement: 2

Key starting position: 12 o'clock  
Key rotation: 90°  
Key ending position: 9 o'clock  
Key when unlocked: Trapped



### Key movement: 3

Key starting position: 12 o'clock  
Key rotation: 180°  
Key ending position: 6 o'clock  
Key when unlocked: Trapped