



CAMLOCK
SYSTEMS

PRODUCT SPECIFICATION

409 Swing Handle

409

ALL METAL, VANDAL-RESISTANT SWING HANDLE WITH GEAR BOX.



OVERVIEW

Vandal-resistant geometric design.

The 409 is a strong, all metal swing handle specially designed with vandal-resistant geometry. This is enhanced by double o-rings for improved ingress protection and anti-corrosion properties. **A range of compatible cams, rods and multi-point locking accessories are available to order alongside this handle.**

Product features

- o Protective vandal-resistant geometry
- o Magnetic dust cap
- o Double skin version available (409-3)
- o Choice of seven different cylinders, including a master key system
- o Ideal for outdoor, unmanned applications

TECHNICAL DATA

Accreditations	RoHS compliant
Locking cylinder	Euro profile
Measurements	198mm (L) x 43mm (W) x 29mm (D)
Material	Zinc alloy
Finish	Black powder coated
Single or double skin	Single and double versions available
Orientation	Left and right hand
Fixing hole measurements	50mm x 25mm, centre holes 100mm apart
Ingress protection	Double o-ring handle and dust cap
IP rating	IP 65

**SMARTER
LOCKING**



TECHNICAL DRAWINGS

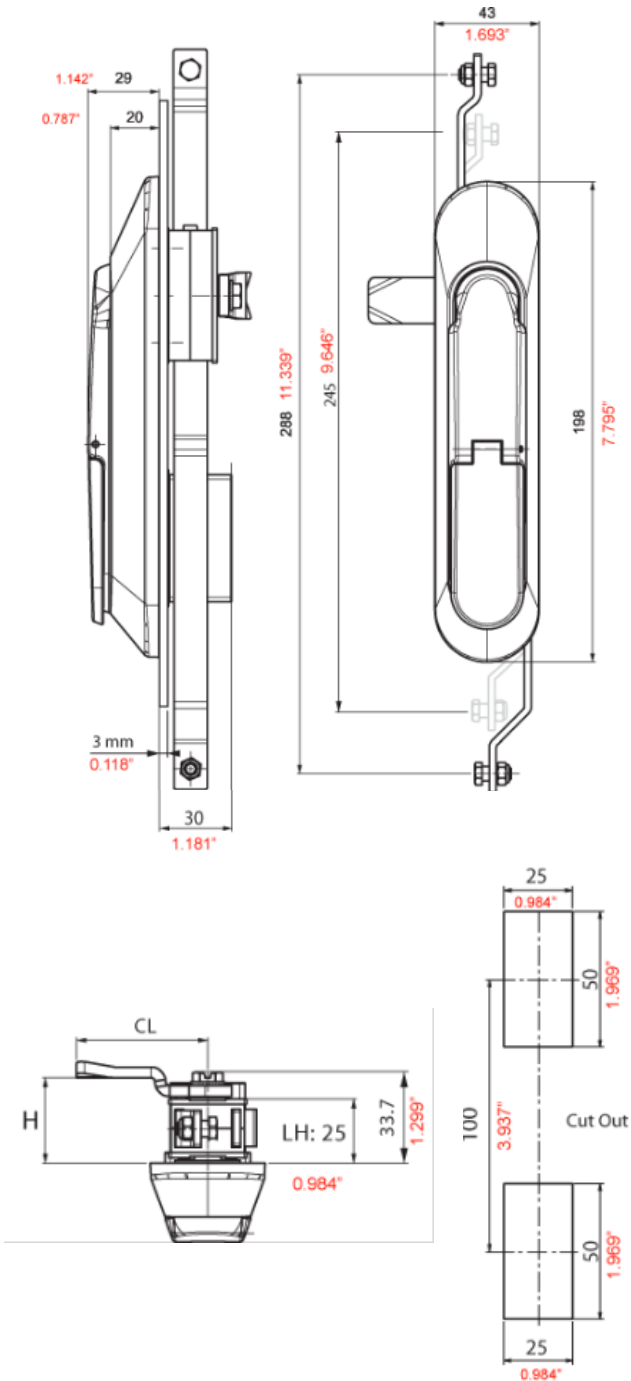

ADDITIONAL PRODUCT IMAGES



Single skin (409-1)



Double skin (409-3)